

NOTE: ILLUSTRATION SHOWN WITH DOUBLE FOOT PLANK, 1x6 RISER (ROWS 2-9), DOUBLE 1x6 RISER (ROW 10), & CHAINLINK GUARDRAIL. PLEASE REFER TO ATTACHED SPECIFICATIONS FOR FEATURES INCLUDED WITH YOUR SPECIFIC BLEACHER.

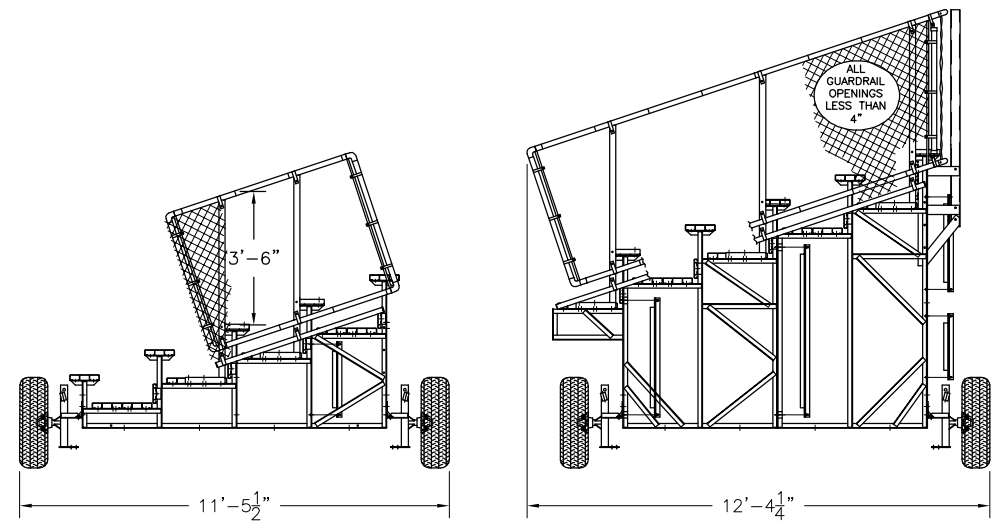

This drawing and all information contained herein is the property of NATIONAL RECREATION SYSTEMS, INC. and is not to be reproduced without express written permission of this manufacturer. We assume no responsibility for unauthorized use of this drawing. National Recreation Systems, Inc. is not responsible for local permits and occupancy requirements.			National Recreation Systems, Inc.	
			P.O. BOX 11487 FORT WAYNE, IN 46858-1487	
SCALE: N.T.S.	APPROVED BY:	DRAWN BY: IMP		
DATE: 3/29/07				
TITLE: 10 ROW NON-ELEV. TRANSPORTABLE BLEACHER SUBMITTAL				
CUSTOMER:			DRAWING NUMBER: SUB-TP10-00B1	