

**NOTE:** ILLUSTRATION SHOWN WITH SINGLE FOOT PLANK ON ROWS 2-3, & DOUBLE FOOT PLANK ON ROWS 4-10, 1x6 RISER ON ROWS 4-9, DOUBLE 1x6 RISER ON ROW 10, & CHAINLINK GUARDRAIL. PLEASE REFER TO ATTACHED SPECIFICATIONS FOR FEATURES INCLUDED WITH YOUR SPECIFIC BLEACHER.

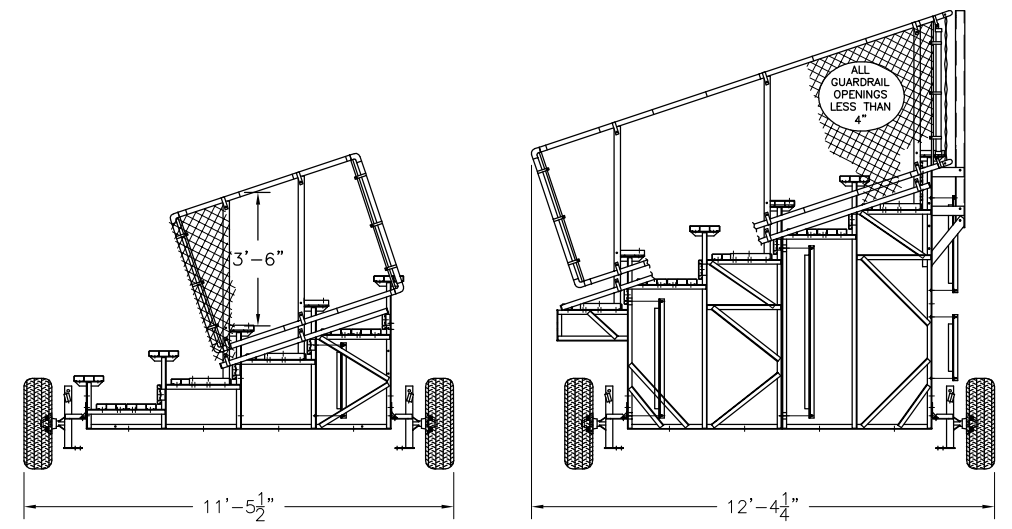

<p>This drawing and all information contained herein is the property of NATIONAL RECREATION SYSTEMS, INC. and is not to be reproduced without express written permission of this manufacturer. We assume no responsibility for unauthorized use of this drawing. National Recreation Systems, Inc. is not responsible for local permits and occupancy requirements.</p>			<p><b>National Recreation Systems, Inc.</b>  P.O. BOX 11487 FORT WAYNE, IN 46858-1487</p>	
SCALE:	N.T.S.	APPROVED BY:	DRAWN BY: IMP	
DATE:	3/29/07			
TITLE:	10 ROW NON-ELEV. TRANSPORTABLE BLEACHER SUBMITTAL			
CUSTOMER:				DRAWING NUMBER: SUB-TP10-00B4